

版本	标识	修改内容	修改日期	签名

FRONT VIEW

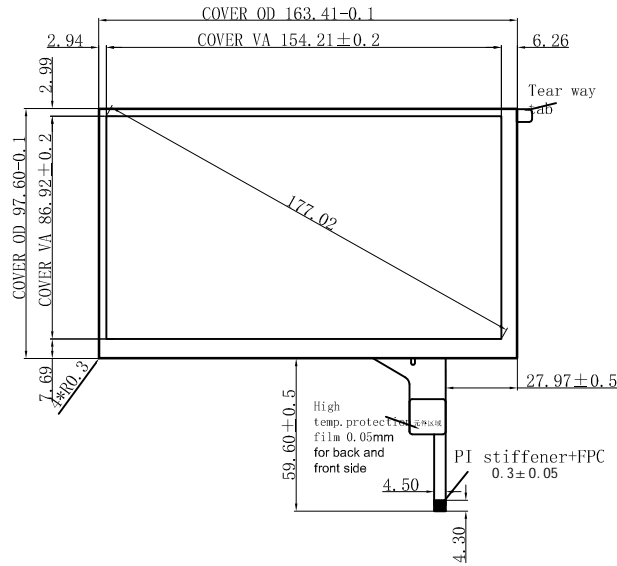

SIDE VIEW

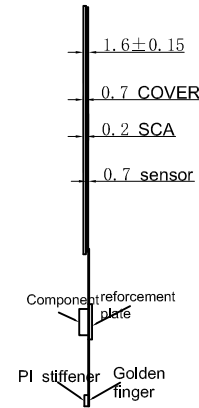

BACK VIEW

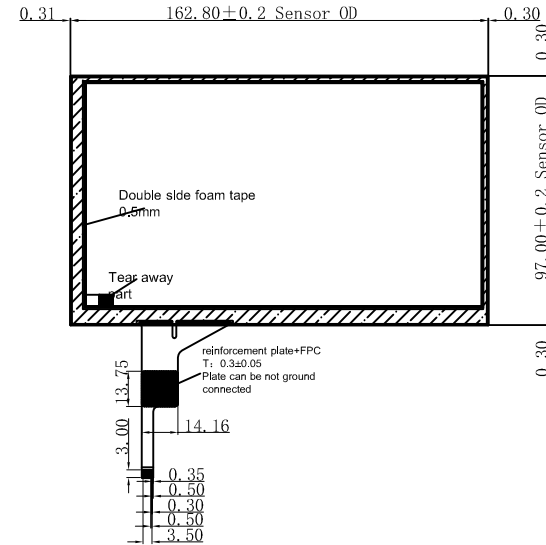

Parameters:

- 1.GLASS+SCA+GLASS+FPC(COF)
- 2.Working voltage:2.8V
- 3.Transparency rate:≥87%
- 4.Surface hardness:≥6H
- 5.Working temp.: -20℃ ~ +70℃ - ≤90%RH
- 6.Storage temp.: -30℃ ~ +80℃ - ≤90%RH
- 7.Unmarked tolerance±0.2mm
- 8.ROHS compliance
- 9.The GAP between LCD and CTP should be over 0.3mm

PIN	Connection
1	GND
2	SCL
3	SDA
4	INT
5	RST
6	NC
7	VDD
8	NC

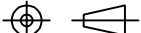
MAXEN ELECTRONICS LIMITED					
制图	zsj	2018.01.20	结构	G+G	HCT581F
审核			比例	1:1	
批准			单位	mm	
		第 1 页 共 1 页		图纸名称	工程图