

标记(mark)	修改内容(revised contents)	签名(signature)	日期(Date)
A版	首发		2013-05-24

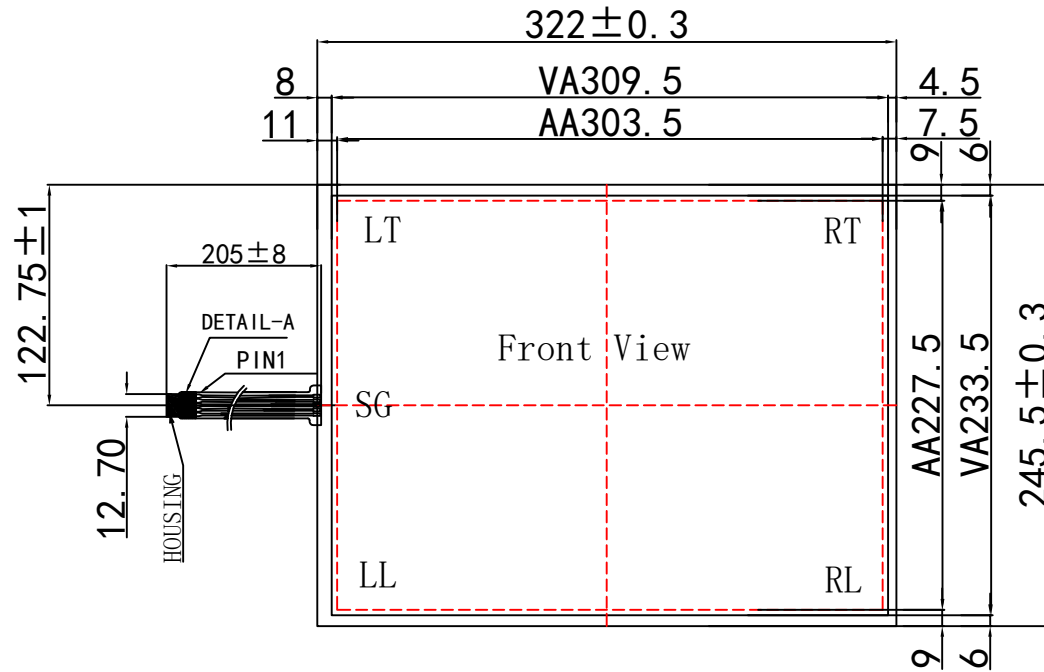

Contact Side:

CONNECTOR PINOUT	
PIN NO.	DESIGNATION
1	RT
2	RL
3	SG
4	LT
5	LL

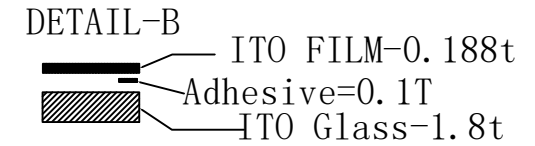
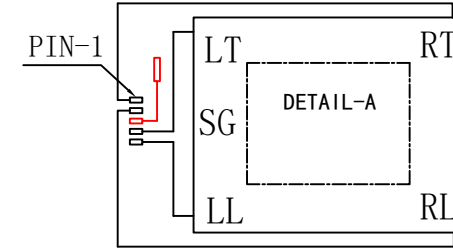

Instruction:

1. Type: Film to Glass + FPC
2. Operating Voltage: 3~7V
3. Response Time: ≤15ms
4. Storage Temperature: -20°C~+50°C/20%~80%
5. Operation Temperature/Humidity: -10°C~+50°C/20%~80%
6. Hitting Life: >10,000,00 Times. 100gf Force
7. Writting Life >1,000,00 Times 100gf Force
8. Connect Material: FPC
9. Film Thickness: 0.188mm
10. Glass Thickness: 1.8mm
11. Light Transmission: 78% ± 8%
12. Force: 100g or less
13. Linearity: ≤ 2.5. %
14. Insulation: ≥ 20MΩ
15. Surface Hardness ≥ 3H (pencil)
16. Unmarked tolerance as ± 0.5

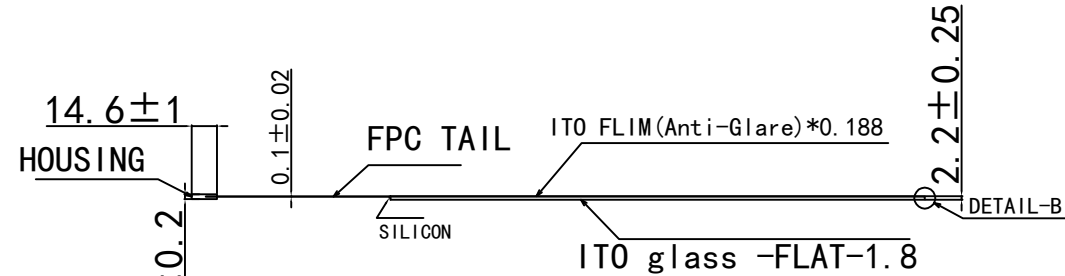
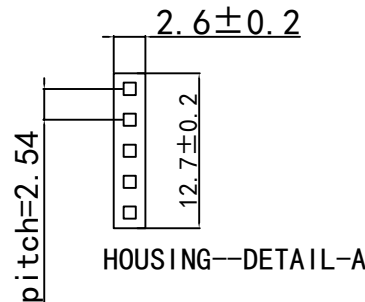

RVE 版本	A	MAXEN ELECTRONICS LIMITED		
TITLE: 产品编号	HCT150A5B009-A			
Customerid: 客户编号		Designed By: 设计		View: 投影方式
Unit: 单位	mm	Checked By: 审核		
Date: 日期	2013-05-24	Approved By: 批准	Scale: 比例	1:1